



“A great product, with great quality, that’s packed with innovation.”

Gary Harrison IMIM
Head of Engineering,
Rivus (Openreach)



TAILOR-MADE FOR YOUR REQUIREMENTS

Our design team has spent years developing and refining our “Virtual proving ground”, where we can rapidly examine any combination of vehicle and platform, and quickly evaluate entirely new platform designs. We have also created processes that allow us to efficiently certify new designs. This means that we can design new products at relatively low cost.

ENTIRELY NEW DESIGNS

Some significant projects included developing bespoke designs for customers like Openreach and National Grid. If you have a specialist requirement and a need for multiple machines, we would be delighted to know more.

EXISTING PLATFORMS ON DIFFERENT VEHICLES

Putting an existing design on a new vehicle is relatively easy, and we would consider doing this

YOUR BENEFITS

- **Mix and match**
Why not combine an existing platform with a different vehicle?
- **Tailor-made.**
Have complete control over specification.
- **Responsive design process**
Consultation with all stakeholders in the project, from finance to end users.
- **You’re in charge**
Regular design reviews, and the opportunity to amend designs after prototype development.
- **You’re in safe hands**
Aldercote has a skilled development team, covering all aspects of the design and development process, including:
 - structural engineering
 - electrical control system design
 - hydraulic control system design
 - control algorithm development
 - composite component development, and
 - complete system integration

for a handful of orders. If you need an access platform on a vehicle make, or model which is not in our range, talk to us. We love a challenge!

PROVEN SUCCESS

We are innovators, and our design team always start from a blank sheet of paper, regardless of how things have been done before.

We were the first to use Strenx steel on small platforms, over a decade ago. Our tripod pedestals have led to class-leading payload, while improving outreach by increasing stabiliser spread. These larger innovations sit amongst hundreds of smaller design ideas which are the result of a continuous drive for improvement.

QUIET, CLEAN, SMOOTH OPERATIONS

Since 2021, all our platforms operate with *E-Drive*, our self-charging hybrid electric system. This allows the engine to be switched off whilst operating your platform and offers a smoother experience with millimetre accuracy compared with conventional platforms.

E-Drive is also 25% faster than comparable platforms so you save on fuel and engine service costs.

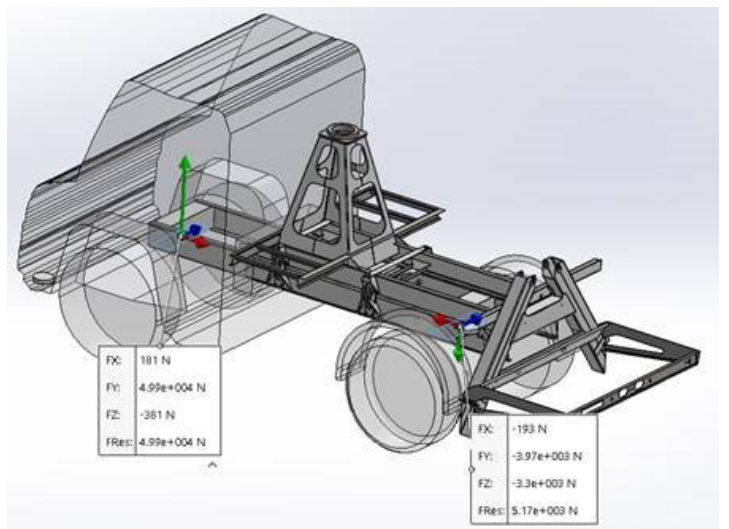
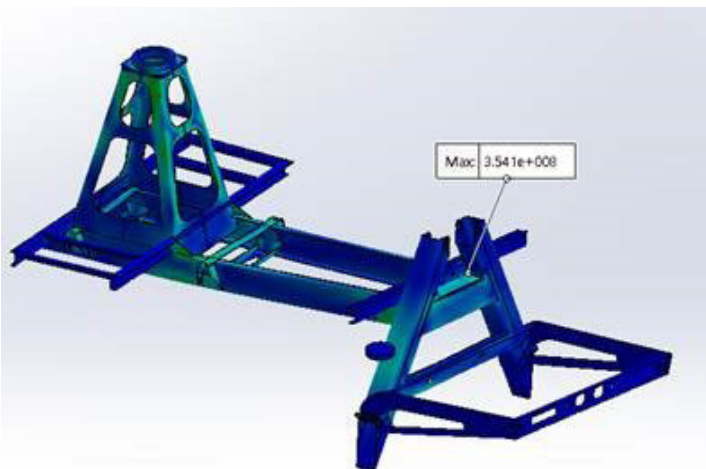

Made in Britain

We are the leading UK manufacturer of vehicle-mounted access platforms. We are proud to design and manufacture high performance products that help our customers build and maintain the nation's infrastructure.

Aldercote is a family run business that puts people first. We show this in our customer care and by valuing every employee for their passion, expertise and individuality.

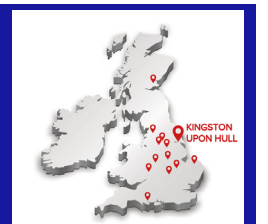

Aldercote Ltd.
The Embankment, Woodhouse Street
Kingston upon Hull, HU9 1RJ, UK.
+44 (0)1482 222377 sales@aldercote.com



© 2023 Registered in England No. 3780815
2023/AL-Custom-EN

